



# DFI's 29th Annual Conference On Deep Foundations

September 29 – October 1, 2004

The Fairmont Hotel

Vancouver, BC, Canada

## DESIGN AND CONSTRUCTION OF A MICROPILE WALL TO STABILIZE A RAILWAY EMBANKMENT

Jim Bruce, Geo-Foundations Contractors, Mario Ruel, CN Rail  
Nadir Ansari & Matthew Janes, Isherwood Associates

### ABSTRACT

This paper presents details of a slope stabilization scheme built in late 2003 at a 12m-high railway embankment in southern Ontario, Canada. The owner, faced with continuing maintenance and safety issues arising from numerous nuisance slides, and residential neighbours in close proximity to the slope, sought new proposals to replace a previous recommendation to cut down all trees and undertake a deep soil nailing scheme. A non-reticulated micropile array with surface cap beam was proposed and built on the south side of the embankment with no tree removal required. A detailed FLAC analysis was completed, using multiple iterations to arrive at the eventual, optimized micropile depth and spacing. Analysis predicted an 18% increase in factor of safety, and short term inclinometer monitoring and performance evaluations in the months since construction so far corroborate the prediction.

### INTRODUCTION

The CN rail tracks at Mile 10.5 Grimsby Subdivision, St Catharines, Ontario, sit atop a 16 metre high earth fill embankment. For 3 years prior to construction of the stabilization works presented herein, the rail tracks had experienced distress from time to time due to some form of progressive failure of the upper regions of the south face of the embankment. Two areas, referred to as Slide 1 and Slide 2 (located approximately 330m east and 250 m east of the Glenridge Avenue overpass, respectively) had experienced numerous nuisance slides that resulted in the deterioration of the track bed and rail alignment. This ongoing instability had resulted in continuous monitoring activity by the railroad and frequent track

cautions and repair, requiring indefinitely imposed speed restrictions through the affected area. Overall the slope deterioration created significant disruption of services and costs. Physical damage included significant transverse deflection of the buried signal and fibre-optic cables, and subterranean sliding of the embankment requiring numerous re-ballasting projects. The persistent movement apparent at the site indicate a slide had taken or was taking place and that the slope would likely continue to move.

By the time the work reported herein was undertaken, Slide 2 had stabilized and was not the subject of any new work. The mechanism of failure at the Mile 10.5

Grimsby Sub was not at any time definitively established. The preliminary analysis provided by Thurber Engineering Ltd indicates the slope should be stable with a factor of safety of 1.23 for a deep seated slide. The initial Isherwood Associates analysis corroborates the Thurber results when the Thurber soil parameters are used. However, with the addition of a reasonable surcharge pressure to represent train traffic and a slight reduction of the proposed soil parameters the embankment stability becomes critical.

Several solutions were proposed to stabilise the slope including: driving of stabilising HP piles, the removal of all trees and placement of micropiles / soil nails, or the removal of the lower section of trees and the placement of a significant toe berm. Sympathetic to the concerns of their residential neighbours, the owner sought a least-impact design solution among the viable options for stabilization. Answering a request for proposals, Isherwood and Geo-Foundations Contractors of Acton, Ontario proposed an alternative solution involving a micropile wall. The micropile wall could be placed near the upper region of the slope, minimising the removal of trees.

Optimising the potential for the proposed micropile construction to improve the existing rail line and supporting earth structure initiated a comprehensive analysis. Both a conventional analysis and a finite difference approach using Fast Lagrangian Analysis of Continua (FLAC) was undertaken. The conventional analysis involved a slope stability study using XSTABL software. This study eventually served to calibrate the FLAC model. The FLAC model was then conducted to explore and optimise

the geometry of the micropile system including loads, moments, lateral movements and top of rail response. It is estimated the stability of the slope was increased by approximately 18 % by the micropile wall construction.

FLAC analysis was performed on a geometry representative of the railway embankment at the location of Slide 1. The soil engineering properties selected for the stratigraphy are based upon the geotechnical report, and properties established during previous, comprehensive analysis performed in representative soils. Previous FLAC type A analysis have correlated well with field monitoring results. Over 30 FLAC analysis directed at providing insight into shoring loads and ground movements adjacent to sensitive structures have been conducted in the Golden Horseshoe area with very good results.

## **Soil Conditions**

A soil investigation was conducted at the Slide 1, Mile 10.5 Grimsby Sub site for CN with the results provided in the report Thurber Engineering Ltd, Geotechnical Report, File Number 16-1-227, dated June 29, 2001 with accompanying borehole logs. The FLAC input soil parameters were derived from both the soils investigation and results of previous comprehensive analysis of Golden Horseshoe area soils. Table 1 indicates the elevations and strata thickness selected for the model based upon the Thurber Engineering investigation. The stratigraphy was based upon the results from Boreholes 01-01, 01-03 and 01-04.

Description	Top Elevation m	Bottom Elevation m	Layer Thickness m
Gravel Ballast	110.0	108.5	1.5
Sand & Gravel Fill	108.5	106.5	2.0
Silty Sand Fill	106.5	103.5	3.0
Silty Clay Fill	103.5	96.5	7.0
Silty Clay Till	96.5	90.5	6
Shale Bedrock (assumed)	90.5		10+

**Table 1.** Soil strata elevations as modelled in FLAC.

Table 2 provides the engineering properties used for the **base level analysis**. The engineering properties presented are calculated or, in the case of dilatancy, are derived from geotechnical publications. The in situ soil stress condition was established assuming a  $K_0$  of 0.6.

Description	Elastic Modulus M Pa *	Poisson's Ratio *	Internal Angle Fric Deg *	C' kPa *	Unit Weight kN/m <sup>3</sup> *	Dilatancy	Bulk Mod M Pa	Shear Mod M Pa	Density kg/m <sup>3</sup>
Gravel ballast	142	0.3	40	0	21	5	118	55	2150
Sand / Gravel	98	0.3	31	0	21.5	0	82	38	2200
Silty Sand Fill	54	0.3	28	0	20.0	0	45	21	2050
Silty Clay Fill	42	0.3	25	0	20.0	0	28	19	2050
Silty Clay Till	280	0.3	36	100	23	0	467	100	2250

**Table 2.** Soil engineering properties assumed for the base line analysis.

### Problem Geometry

Figure 1 indicates the geometry as modeled in the analysis. Section 2, station 0+175.6 at the approximate mid point of the slide area was analysed. The geometry models the embankment looking East along the axis of the rail lines. The top of the embankment was assumed to be at elevation 110.0 m and the bottom of embankment on the South side at elevation 94.0 m for a total

embankment height of 16 m. The soil strata was assumed to be dewatered to the elevation of the ditch at 94 m. Figure 2 provides a representation of the FLAC grid with the micropiles in place. The FLAC grid is 100.0 m wide and 30.0 m high. The grid was not symmetrical about the centre line of the excavation, but follows the contour of section 2, slide 1. Micropiles are spaced at 0.5 m centres and assume a Titan 40/20 injection anchor within a 125 mm diameter grout column. The entire grid is modelled but

the figure indicates only the south embankment and non reticulated micropile wall structure for clarity. The micropile cap beam structure is modelled as a reinforced concrete beam with a thickness of 450 mm, width of 600 mm,

elastic modulus of  $4.5 \times 10^4$  MPa and a mass of  $2500 \text{ kg/m}^3$ . See figure 3 for a detail showing the pile cap geometry as constructed.

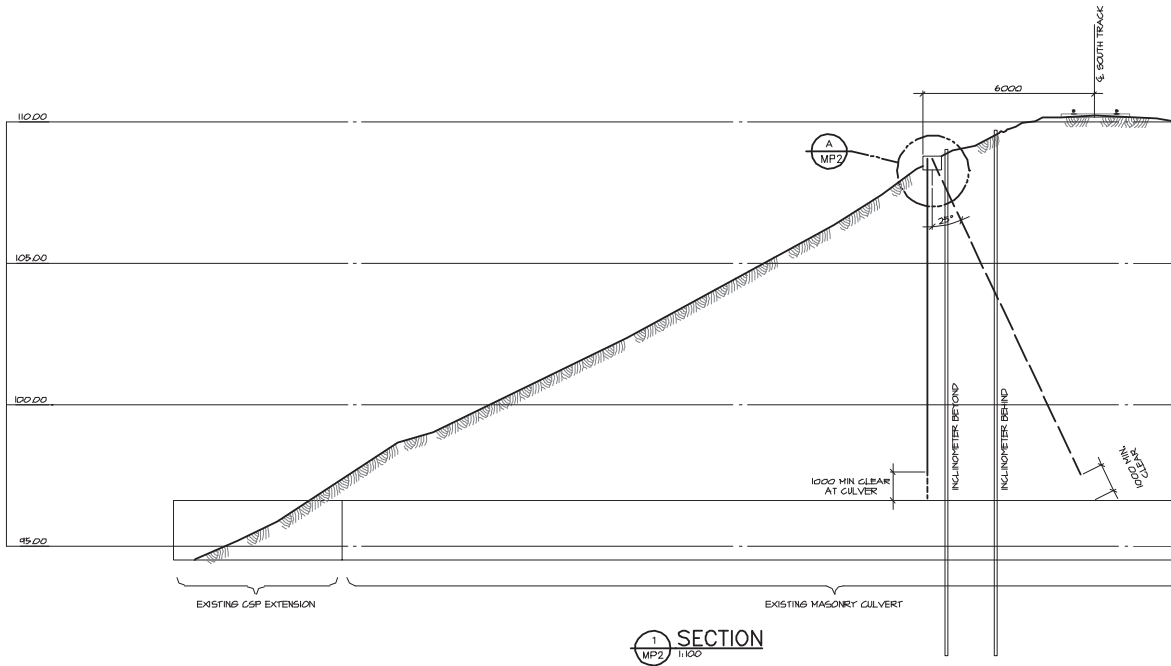

**Figure 1** Geometry as modeled in the analysis.

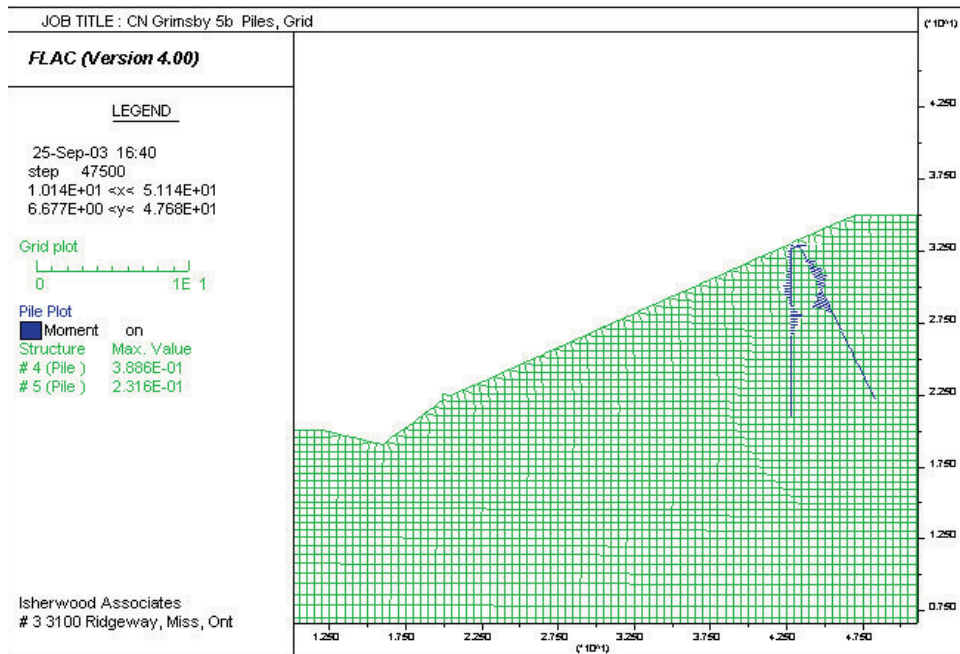

**Figure 2** FLAC grid with the micropiles in place

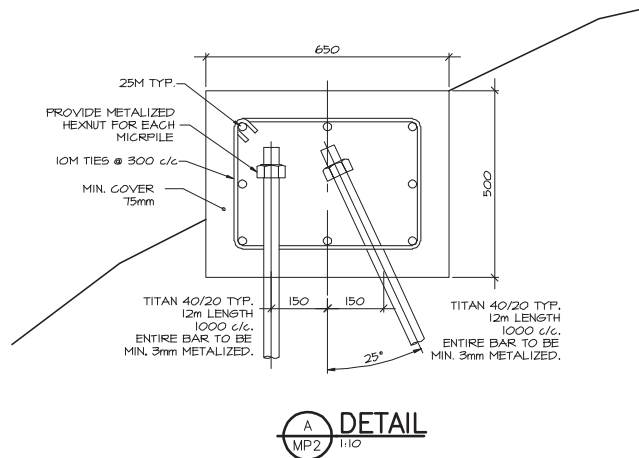

**Figure 3** Detail Micropile cap.

### Analysis

The two-dimensional Fast Lagrangian Analytical Method (FLAC) was selected for the analysis of the proposed micropile construction. The method uses the explicit finite difference approach to solve a series of governing equations written at discrete points within a grid. A Lagrangian approach to grid deformations is used. The method has been used for geotechnical and mining engineering problems for over 15 years and has been well documented in geotechnical literature.

The analysis is conducted in stages representative of the sequenced nature of the conditions developing at the site. Calculations within the FLAC model are performed in 'steps' representative of time. First the embankment is modelled and permitted to consolidate through a number of steps. During this phase potential instability of the slope is witnessed. The construction of the non reticulated micropile wall is then modelled and the slope is analysed through additional steps. At each stage in the progression calculations are conducted to

provide an equilibrium condition from which soil and structure behaviour may be obtained. The results provide soil stress, strain and structure displacements and axial, shear and moment forces.

The embankment and proposed micropile wall was modeled for the purpose of determining the improvement in the stability of the embankment and the probable movements and loads of the micropile structure. The approach consisted of determining the baseline soil properties of the strata that would result in critical embankment stability, FOS  $\leq 1.0$ . The soil properties within the upper ballast and sand / gravel layers were assumed to be high enough to be of secondary importance in reaching the critical condition. The engineering properties of the silty sand and silty clay fills were considered to most likely influence overall slope stability and were lowered gradually until the critical state occurred. This consisted of reducing the internal angle of friction for each soil layer by 1 degree, re-running the analysis and reviewing the results.

It was initially determined that the embankment surface exhibited unstable conditions and was predisposed to excessive raveling failure. The model was reprogrammed to provide a 0.5 m thick cohesive zone over the slope surface to prevent these surface failures. This is considered a reasonable assumption due to the presence of topsoil and vegetation on the slope.

Having established the critical soil parameters using both conventional limit equilibrium analysis and FLAC the results of each method were compared and contrasted. The conventional XSTABL analysis indicated slope failure at or

about the same depth as the FLAC analysis and under similar soil conditions. However, the XSTABL analysis provides a family of failure curves (or near failure curves with a FOS of 1.0) whereas the FLAC analysis indicated what appeared to be a single shallow (4 to 6 m depth) seated failure surface with each run, see Figure 4.

Using the critical condition soil model a non reticulated micropile wall was modelled and the embankment was re-analysed. The results indicated a stable embankment condition had been achieved. Successive runs were conducted, again lowering the internal angle of friction in each of the sandy silt and silty clay fill soils until a new critical

condition was achieved. The relationship between the original and the 'new' post micropile wall embankment stability and failure soil properties were compared. The increase in slope stability was established by comparing the relationship between the Tan of the internal angle of friction of the original soil properties and the those of the 'new' post micropile wall soil properties at the critical condition. A combined reduction in Phi angle ( $\Phi$ ) of  $2^\circ$  in the silty sand ( $26^\circ$ ) and  $3^\circ$  in the lower silty clay fill ( $22^\circ$ ) was achieved while maintaining a stable micropiled embankment, see Figure 5. When the phi angle was reduced a further degree, to  $21^\circ$  in the lower silty clay fill the embankment began to exhibit global distress, Figure 6.

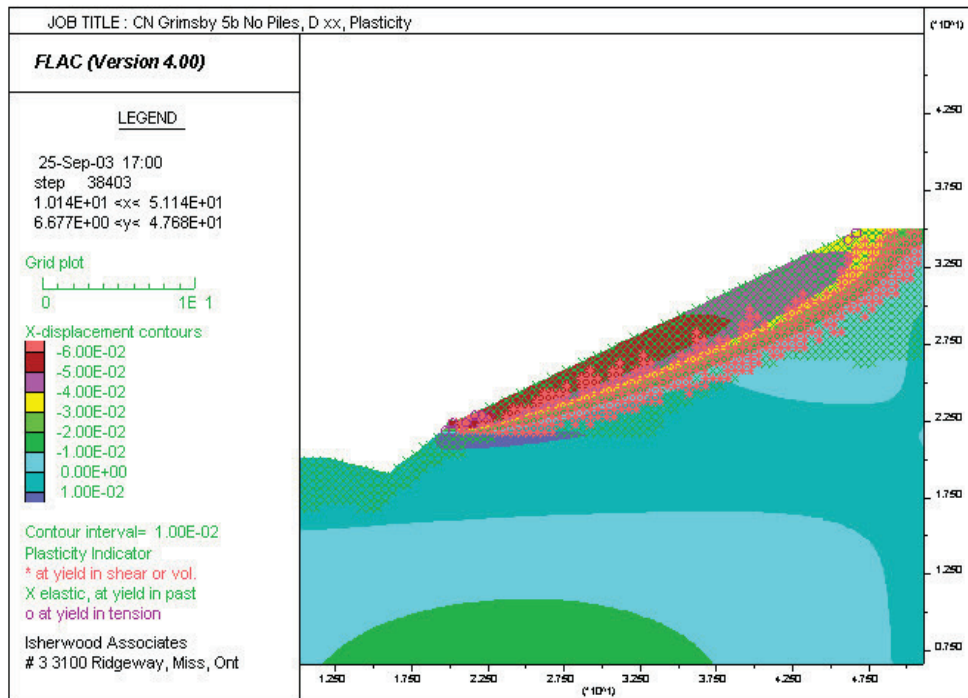

Figure 4. Typical failure profile with reduced soil  $\Phi$  properties.

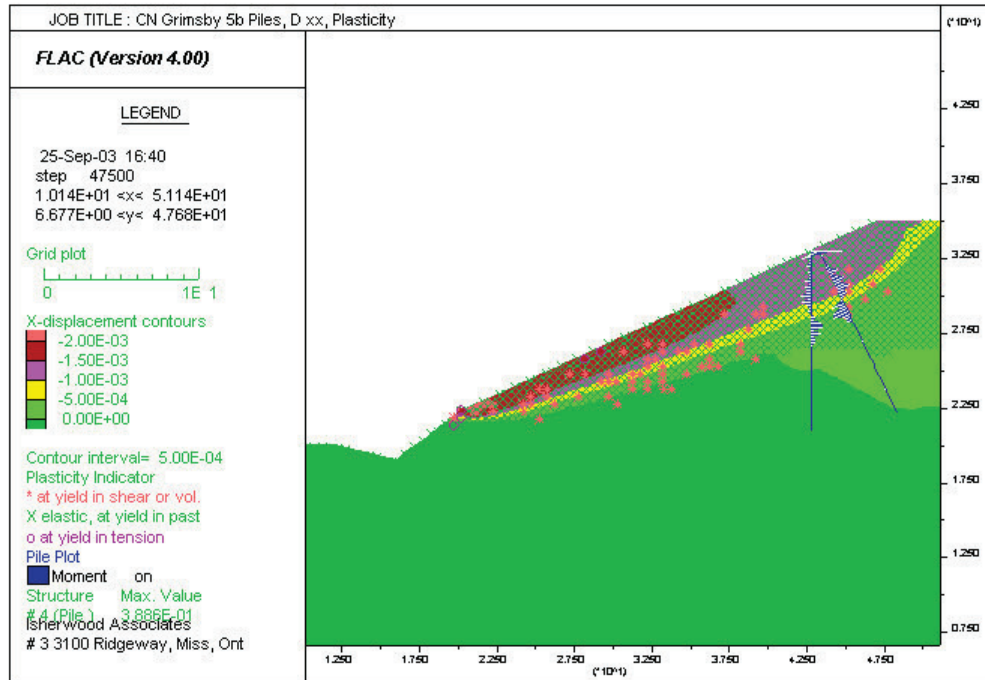

Figure 5. Embankment analysis with optimised micropiles and 3° reduction in  $\Phi$ .

A  $\Phi$  angle of 21.5° was investigated and showed significant deformation below the micropile wall, but a stable condition above. For the purpose of evaluating the improvement in slope stability a  $\Phi$  angle of 25.5° in the clayey silt is considered stable without micropiles and a  $\Phi$  angle of 22° with micropiles. A simplified but reliable measure of slope stability is to take:

$$\begin{aligned} \text{FOS} &= \frac{\tan \Phi \text{ soil}}{\tan \text{ slope angle}} \\ &= \frac{\tan 25.5}{\tan 22} = 1.18 \end{aligned}$$

Where  $\tan \Phi$  soil is for the critical soil layer.

Therefore the improvement in the factor of safety may be taken as 18 %.

The study indicates lateral deflection of the micropile wall structure occurs in the direction of the downward slope on the order of 1-2 mm for the critical case. The south rail tracks, which rest upon this elastically mobilized soil mass are also shifted laterally on the order of <1 mm towards the south embankment. The movement of the slope soils in the region of the micropile wall are on the order of 5 mm.

The failure case for the micropile wall, when the  $\Phi$  angle was reduced by 4° indicates extensive soil and pile movements downslope on the order of 100mm. Pile movements increase to 25 mm and micropile bending exceeds the capacity of the micropiles.

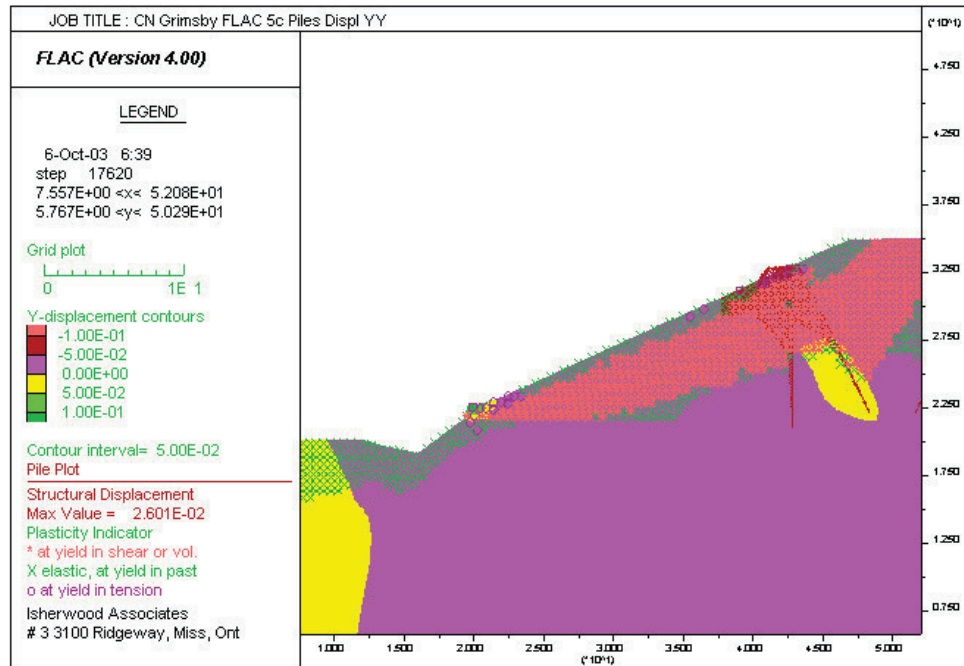

Figure 6. Embankment analysis with optimised micropiles and 4° reduction in  $\Phi$ .

## Installation

The design-build contractor, Geo-Foundations, previously completed 2 soil nail projects for CN - Fairchild Creek Viaduct in September, 2001, and Dundas Subdivision in November, 2002. Out of these past successful projects, the contractor was approached by CN to provide budget pricing for the Grimsby problem. Conventional solutions involving the driving of large piles or a broad expanse of micropiles / soil nails were thought impracticable by CN personnel due to the terrain (small footprint available for letdown; logistically challenging mobilization and handling of single piece piles, etc). Furthermore, the estimate for the previously prescribed 18m deep soil nails on a 2m x 2m grid covering 60m longitudinal x 12m down slope exceeded \$650,000 CAD, with the added consequence of having to cut every tree buffering the embankment from the neighbouring mid-rise senior's

residence. The proposed micropile wall alternative became attractive for a number of reasons including: a reduced price of only \$375,000 including the design engineering presented herein, supply and long term monitoring of inclinometers; no loss of trees; a 3 week construction schedule; relatively quiet installation; and, a small footprint operation resulting in zero interruption to rail operations.

The contractor installed the micropiles using a Hütte HBr 605d rig placing Titan 40/20 injection anchors. A 115 mm soil bit was used with continuous grout flush and top hammer rotary percussion. This particular installation process was selected for the combination of enhanced geotechnical performance of the micropiles and the high attenuation of installation energy in the proven fragile embankment soils. The embankment was notched very slightly in the area of the micropile wall to accommodate



positioning of the rig and construction of the micropile cap. Figure 7 shows the micropile installation. Note the presence of passing rail cars in Figure 7 – rail service was not interrupted at any time

due to micropile wall construction. Figure 8 shows the re-dressing of the embankment following the completion of the pile cap placement and stripping of forms.



**Figure 7.** Installation of micropiles during track operation.



**Figure 8.** Embankment grading following pile cap installation.

## Performance

Inclinometers were placed approximately 1m up slope from the micropile wall and are to be monitoring over a three year period. The inclinometers are spaced approximately 10 m apart, on either side of the midpoint of the length of the 60 m wall. The initial readings were taken in December of 2003. The first set of follow up readings was taken in the spring of 2004. Due to vandalism of the inclinometer caps interruption of data acquisition was experienced. Follow up visits to repair the inclinometer top sides enabled additional readings to be taken.

The results of the inclinometer readings are provided indicated in Figure 9.

It may be seen that the top of the inclinometer casings have been moved due to vandalism. In addition it appears that inclinometer 1 has not moved appreciably whereas inclinometer 2 indicates up to 7.5 mm of movement down-slope. This movement is probably due to continued movement of the shallow slide. The FLAC analysis indicated that soil movements of 7.5 to 10 mm would be required to fully mobilise the resistance of the micropile wall.

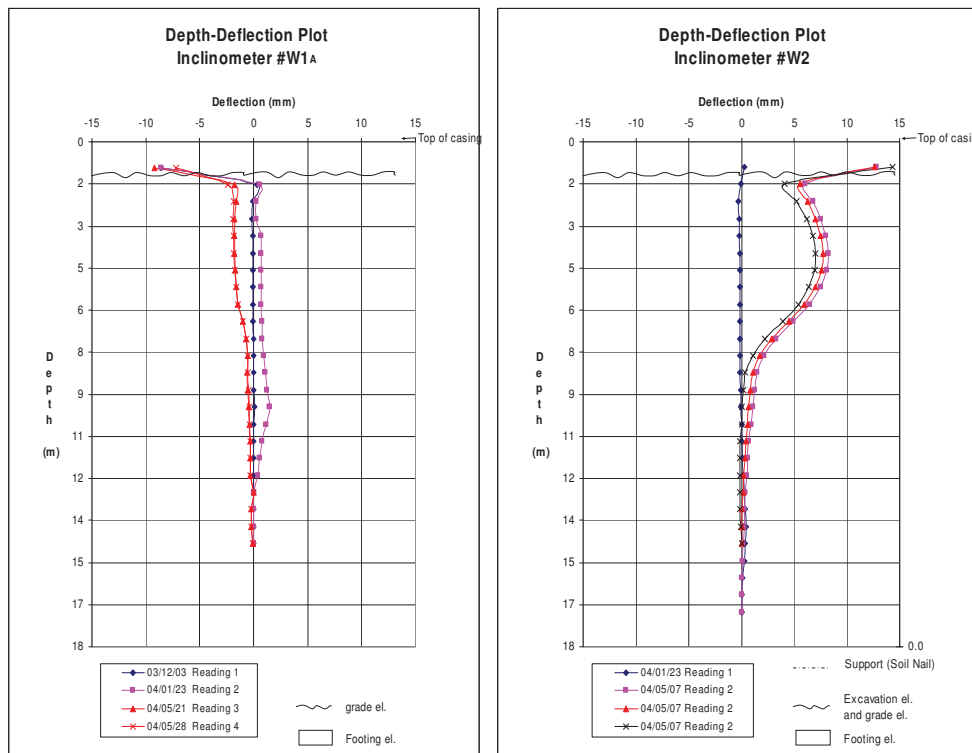

Figure 9 Up-slope inclinometer readings.

## Conclusion

The design build solution provided value to the owner on a number of levels. The low impact construction technique prevented the deforestation of the

embankment preventing disruption of the relationship with the nearby senior's home. In addition the construction method prevented interruption of service to the existing lines. The favoured driven pile stabilisation would have required